

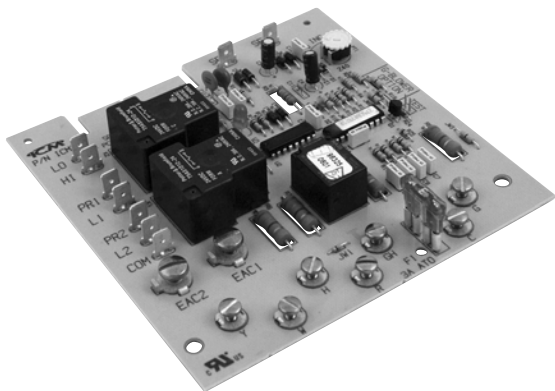

# ICM 275 Fan Control Center



## Replacement Description

The ICM275 Gas Furnace Control Center is a new generation control for the replacement market.

The ICM275 Gas Furnace Control Center is designed to function similarly to previous control center designs, while incorporating some of the latest features in furnace control center technology.

It is a direct replacement for the following Carrier control center part numbers: HH84AA021, HH84AA001, HH84AA003, HH84AA005, HH84AA009, HH84AA014, HH84AA015, or CES0110019.

## Installation, Operation & Application Guide

For more information on our complete range of American-made products – plus wiring diagrams, troubleshooting tips and more, visit us at [www.icmcontrols.com](http://www.icmcontrols.com)



## Table of Contents

Specifications .....	1
Introduction .....	1
Safety Considerations.....	1
Operational Differences and Added Features .....	2
Installation Instructions.....	2
ICM275 Component Layout .....	3
Wiring Diagram.....	4
Troubleshooting .....	5

## Specifications

- **Input Voltage**
  - Terminals: PR-1, PR-2, L1, L2 and COM .....120 VAC
  - Terminals: SEC-1 and SEC-2 ..... 18-30 VAC
- **Line Frequency** ..... 60 Hz
- **Operating Temperature** ..... -40°F to +176°F
- **Maximum Operating Humidity** ..... 95% R.H.  
Non-condensing @ 50°C
- **Time Delays**
  - Heat **ON** .....60 Seconds
  - Heat **OFF** .....60-240 Seconds
  - Cool **OFF** (R18 Cut).....90 Seconds

## Introduction

This application guide covers the installation of the Gas Furnace Control Center, Part No. ICM275, in an intermittent ignition, induced draft, or condensing gas furnace.

## Safety Considerations

Installing and servicing heating equipment can be hazardous due to gas and electrical components. Only trained personnel should install or service heating equipment.

Untrained personnel can perform basic maintenance functions such as cleaning coils, or cleaning and replacing filters. All other operations should be performed by trained personnel only. When working on heating equipment, observe precautions in the literature, on tags, and on labels attached to the unit.

Follow all safety codes. Wear safety glasses and work gloves. Have a fire extinguisher available.

**CAUTION!:** *Before beginning the installation or modification, be sure the main electrical disconnect switch is in the OFF position.*

**CAUTION!:** *Failure to carefully read and follow these instructions before servicing or operating this control, could result in personal injury, death and/or property damage.*

## Operational Differences and Added Features

The following is a description of the slight operational differences and added features. Refer to ICM275 Component Layout (Page 3) for location of control center components.

### **Operation with new blower and humidifier relays:**

The previous design control centers used a SPST-NC or DPST-NC heating fan relay (HFR of E2) and a DPDT cooling fan relay (CFR or 2F) for blower and humidifier terminal operation. This new control center uses a SPST-NO blower relay (BLWR) and a SPDT blower speed change relay (hi/lo) for blower operation, and a SPST-NO humidifier relay.

1. The low-speed blower will not operate on a transformer failure as on previous designs.
2. If **JW1** jumper is cut between **R** and **GH** terminals, a constant low-speed blower will occur without any thermostat inputs to the control center. A **GC** or **Y** signal to the control center **will not** bring on the hi-speed blower for cooling operation. **JW1** jumper **must not** be cut on cooling applications.
3. The humidifier **H** terminal is energized with low-speed blower operation. In cooling operation, the humidistat and humidifier water supply should be turned off to ensure the humidifier does not operate.

### **24 volt circuit protection:**

An automotive type, 3 amp fuse is provided to protect the transformer and thermostat from shorts in the low-voltage circuitry. An open fuse will initiate a constant low-speed blower. Refer to the ICM275 Component Layout (Page 3) for location on control center.

### **Low-speed continuous "G" blower and 90-second hi-speed blower OFF delay option:**

**Resistor (R18)** on the control center can be cut to achieve heating speed continuous blower with a thermostat (**R-G**) call and a hi-speed blower with a 90 second OFF delay with a thermostat (**R-Y**) call.

**CAUTION!:** *Do not cut R18 on **twinned** furnace applications.*

## Installation Instructions

**CAUTION!:** *Verify power is removed from the control by removing fuse or turning off circuit breaker.*

1. Disconnect wiring from blower control center. Tag each wire as it is disconnected from the old furnace control center. Disconnect **all** wiring hookups.
2. Remove existing blower control center.
3. Install the **ICM275** fan control center into the control center box. Be sure that the top edge of the **ICM275** is in the mounting slot, just like the original board.

**CAUTION!:** *If the **ICM275** is not installed correctly (i.e.: behind the slot), an electrical short could occur.*

4. Reconnect all of the wire(s) that were removed in Step 1 above, to the proper terminals.
5. Turn power to ON position and check unit sequence of operation per unit installation instructions.
6. These instructions must be placed with the original unit instruction packet, or with the unit for future reference.

# Blower Operating Modes

Input From Thermostat	Resistor (R18) Uncut	Resistor (R18) Cut
W	Lo-speed heating blower*	Lo-speed heating blower*
G	Hi-speed cooling blower	Lo-speed heating blower
Y	No blower	Hi-speed cooling blower**

\* 60-second ON delay and 60-240 second adjustable OFF delay

\*\* 90-second OFF delay

## Component Layout

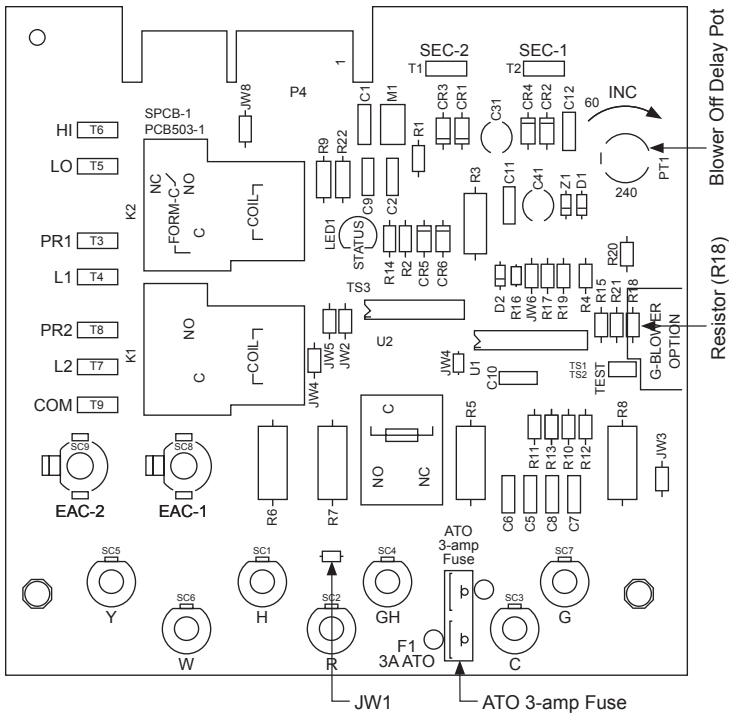

# Wiring Diagram

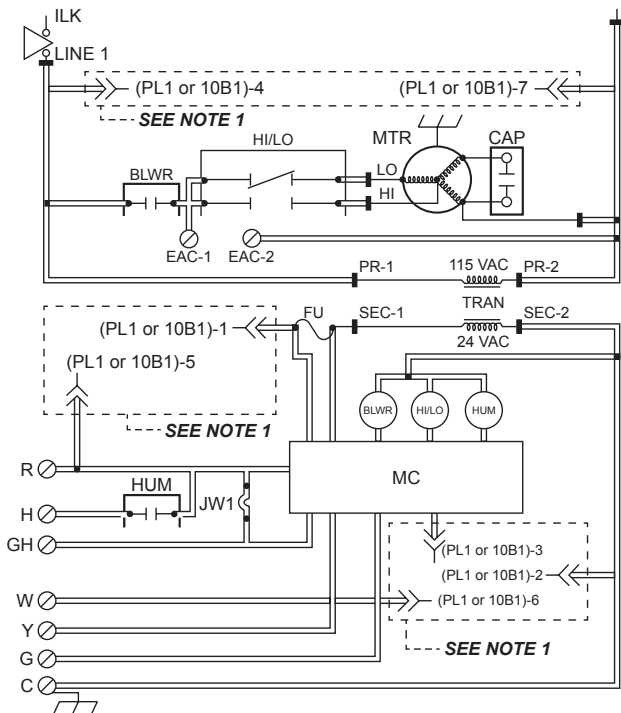

## LEGEND:

CAP	Run Capacitor	⇒ Plug Receptacle	— Factory Wiring (115 VAC)
TRAN	Transformer	○ Junction	— Factory Wiring (24 VAC)
JW1	Jumper Wire	○ Unmarked Terminal	— Conductor on PCB
MTR	Motor, Blower	■ Terminal PCB	⊗ Screw Connector
MC	Microcontroller		⌋ Equipment Ground
FU	Fuse (ATO 3-amp)		
HI/LO	Blower Motor Speed Change Relay (DPST)		
HUM	Humidifier Relay (SPST-NO)		
BLWR	Blower Motor Relay (SPST-NO)		
ILK	Switch, Blower Door Interlock (SPST-NO)		

## Note 1:

PL1 and 10B1 indicates 7-PIN edge connector terminations that connect to control center. Refer to unit wiring diagram for specific unit wiring from control center edge connector.

## Troubleshooting

**WARNING!:** *High voltage! Troubleshooting this fan control board involves working with high voltage which can result in personal injury, death and/or property damage.*

**CAUTION!:** *Always disconnect power by removing a fuse or opening a circuit breaker before doing continuity checks. Verify power is not present before troubleshooting.*

**CAUTION!:** *Troubleshooting tasks should only be performed by those trained to install or service HVAC equipment.*

Symptom	Remedy
Continuous low speed blower	<ul style="list-style-type: none"><li>• Check for open fuse</li><li>• Check for open limit</li><li>• Check for 24 VAC at R and C terminals</li><li>• Check if JW1 is cut</li><li>• Check edge connector slot 1 and slot 5; with no power applied and the edge connector removed, there should be continuity between edge connector slot 1 and slot 5</li></ul>
Blower speed not correct	<ul style="list-style-type: none"><li>• Check if R18 is cut</li><li>• Check wiring of LO and HI terminals</li></ul>
No fan for heating or cooling	<ul style="list-style-type: none"><li>• Check for 24 VAC at SEC1 and SEC2</li></ul>
No fan delays	<ul style="list-style-type: none"><li>• Verify test pins are not shorted</li></ul>
No fan on heat call	<ul style="list-style-type: none"><li>• Check for 24 VAC at R and C terminals</li><li>• Check for 24 VAC at SEC1 and SEC2</li><li>• Check edge connector slot 3 and slot 6; with no power applied and the edge connector removed, there should be continuity between edge connector slot 3 and slot 6</li></ul>
Status LED blinking	<ul style="list-style-type: none"><li>• Status LED blinks when 24 VAC is applied to SEC1 and SEC2; there are no fault flash codes for this control</li></ul>
Intermittent fan operation	<ul style="list-style-type: none"><li>• Check for constant 24 VAC at R and C terminals</li><li>• Bypass thermostat and test operation of fan control; with no power applied, remove wires to thermostat; use a jumper wire to initiate a call for heat/cool blower; if operation is correct, thermostat or thermostat wire is faulty</li></ul>

# **ONE-YEAR LIMITED WARRANTY**

The Seller warrants its products against defects in material or workmanship for a period of one (1) year from the date of manufacture. The liability of the Seller is limited, at its option, to repair, replace or issue a non-case credit for the purchase prices of the goods which are provided to be defective. The warranty and remedies set forth herein do not apply to any goods or parts thereof which have been subjected to misuse including any use or application in violation of the Seller's instructions, neglect, tampering, improper storage, incorrect installation or servicing not performed by the Seller. In order to permit the Seller to properly administer the warranty, the Buyer shall: 1) Notify the Seller promptly of any claim, submitting date code information or any other pertinent data as requested by the Seller. 2) Permit the Seller to inspect and test the product claimed to be defective. Items claimed to be defective and are determined by Seller to be non-defective are subject to a \$30.00 per hour inspection fee. This warranty constitutes the Seller's sole liability hereunder and is in lieu of any other warranty expressed, implied or statutory. Unless otherwise stated in writing, Seller makes no warranty that the goods depicted or described herein are fit for any particular purpose.



**7313 William Barry Blvd., North Syracuse, NY 13212**  
**(Toll Free) 800-365-5525 (Phone) 315-233-5266 (Fax) 315-233-5276**

[www.icmcontrols.com](http://www.icmcontrols.com)

LIA13-2