

Features

- Direct Spark Ignition (DSI) control board
- Microprocessor-based
- Controls inducer motors, air cleaner (if equipped), humidifier (if equipped), spark ignitor and the gas valve
- 100% lockout safety feature
- Monitors timing, trial for ignition, vent pressure switch, limit switches (main and over-temperature switches in series), flame sensing and lockout
- Compatible with LP or natural gas
- LED indication for status and fault codes to aid in troubleshooting
- Replaces: Rheem 62-24140-04



Safety Considerations

Only trained personnel should install or service heating equipment. When working with heating equipment, be sure to read and understand all precautions in the documentation, on labels, and on tags that accompany the equipment. Failure to follow all safety guidelines may result in damage to equipment, severe personal injury or death.

Introduction

The **ICM292A** DSI gas ignition control replaces the following Rheem model: 62-24140-04. The **ICM292A** has incorporated LED diagnostics to assist in troubleshooting. Fault code information can be found in this application guide. Please keep this application guide with the furnace installation manual for future reference.

Specifications

- **Line voltage:** 120 VAC
- **Control voltage:** 18-30 VAC, 60 Hz
- **Power consumption:** 0.3A plus gas valve current @ 24 VAC
- **Operating temperature:** -40°C (-40°F) to 75°C (176°F)

Outputs

- **Gas valve:** 3A Pilot Duty @ 24 VAC
- **Draft inducer motor:** 3A max., 1/6HP @ 120 VAC
- **Cool blower speed:** 15A max., 1/2HP @ 120VAC
- **Heat blower speed:** 14A max., 1/2HP @ 120 VAC
- **Fan blower speed:** 12A max., 1 HP @ 120 VAC
- **Heat/cool single-speed:** 10 A max., 1/2 HP @ 120VAC
- **Electronic Air Cleaner:** 10 A max., 1HP @ 120 VAC

- **Humidifier:** 3A max., 1/6HP @ 120 VAC

LED indicators

- **Power, green LED:** PWR
- **Status, green LED:** OK
- **Flame status, yellow LED:** FLAME

Timing

- **Pre-purge:** 30 seconds
- **Trial for ignition:** 7 seconds
- **Retries:** Two groups of two: 1st trial, 30 seconds delay, 2nd trial, 3 minutes delay, 3rd trial, 30 seconds delay, 4th trial, Lockout.
- **Lockout:** 1 hour
- **Heat blower ON delay:** 20 seconds
- **Post-purge:** 10 seconds
- **Heat blower OFF delay:** Toggle switches SW1 and SW2

TIME	SW1	SW2
90 sec	OFF	ON
120 sec	OFF	OFF
160 sec	ON	OFF
180 sec	ON	ON

Operation

A W call from the thermostat engages the Inducer Draft motor, provided that the system safety switches (Main and Over-temperature switches in series) are closed. The Vent Pressure switch closes. After a 30 second pre-purge, gas valve and spark are engaged. The ignitor turns off after flame is sensed or at the end of the trial for ignition, whichever comes first. If flame is not sensed, the board performs a retry. When flame is sensed, previous retries are cleared. After the Heat blower On-delay, the Blower motor engages at HEAT speed. When W call is satisfied, the gas valve is turned off. The Inducer motor turns off after 10 seconds and Blower motor turns off according to Heat Blower Off-delay setting.

A G call from the thermostat will engage Blower motor without delay at FAN speed. It disengages without delay when G call is removed. A Y call from the thermostat will engage Blower motor without delay at COOL speed. It disengages 45 seconds after Y call is satisfied.

Electrostatic Discharge (ESD) Precautions

CAUTION!

Use caution when installing and servicing the furnace to avoid and control electrostatic discharge; ESD can impact electronic components. These precautions must be followed to prevent electrostatic discharge from hand tools and personnel. Following the precautions will protect the control from ESD by discharging static electricity buildup to ground.

1. Disconnect all power to the furnace. Do not touch the control or the wiring prior to discharging your body's electrostatic charge to ground.
2. To ground yourself, touch your hand and tools to a clean, metal (unpainted) furnace surface near the control board.
3. Service the furnace after touching the chassis. Your body will recharge with static electricity as you shuffle your feet or move around, and you must reground yourself.
4. Reground yourself if you touch ungrounded items.
5. Before handling a new control, reground yourself; this will protect the control. Store used and new controls in separate containers before touching ungrounded objects.
6. ESD damage can also be prevented by using an ESD service kit.

Remove Existing Control

CAUTION!

To service control, and prior to disconnection, label all wires. Failure to do so may result in wiring errors that can cause dangerous operation.

1. Turn thermostat to OFF position or set it to the lowest possible setting.
2. Turn OFF electrical supply to furnace.
3. Turn OFF gas supply to furnace.

✱ **CAUTION:** Failure to turn off gas and electric supplies can result in explosion, fire, death, or personal injury.

4. Remove furnace blower and control access doors.
5. Disconnect thermostat wires and humidifier wires (if equipped with a humidifier).
6. Disconnect line voltage, blower, electronic air cleaner wires (if equipped), and transformer wires.
7. Remove screws and any other fasteners, and the old circuit board.
8. Examine control and control box to check for water stains.
9. Make repairs if any sources of water leakage are found. Be sure to check humidifiers, evaporator coils, and vent systems in the area of the control.

Install New Control

1. Ground yourself. When handling circuit board, hold it by the edges.
2. Fasten circuit board with retaining screws.
3. Connect all line voltage, low voltage, and accessory wires.
4. Verify the sequence of operation.

LED Fault Codes

LEDS	Flashes	Fault Condition
OK (GREEN)	ON	Normal operation
	1 Flash	Ignition lockout (4 failed trials/5 flame losses)
	2 Flashes	Pressure switch stuck open
	3 Flashes	Limit switch open
	4 Flashes	Pressure switch stuck closed
	5 Flashes	Twin fault
	6 Flashes	Brownout voltage
	7 Flashes	Hot and neutral reversed or no ground
	Rapid Blink	Flame out of sequence
	OFF	Gas valve relay short
FLAME (YELLOW)	Rapid Blink	Flame out of sequence
	Slow Blink	Low flame or no flame
	ON	Flame present

Lockout

The control will enter a 1-hour lockout if:

1. The Gas Valve is sensed on when it should not be.
2. Flame is sensed out of sequence.
3. Flame is not sensed during 4 consecutive trials for ignition.
4. Flame is lost after successful ignition 5 times in one W call.

Note: All lockout types can be cleared by cycling power to the board. Ignition lockouts can also be cleared by cycling the W call.

Troubleshooting Tips

Weak or intermittent spark: Make sure the furnace frame is grounded to earth ground. Ensure that the 24 VAC common is grounded to Earth ground. Check or replace the spark igniter. Check the primary and secondary voltage of the transformer for proper voltage.

Flame Loss: Check, clean, or replace the flame sensor. Check pressure switch.

No flame/ignition failure: Ensure that the 24 VAC common is grounded to Earth ground. Check, clean, or replace the flame sensor. Check or replace the spark igniter.

Flame out of sequence: Flame out of sequence represents a scenario where flame is sensed while the gas valve is closed. The control enters lockout.

No ignition, main blower runs continuously: Check the high temperature limit switch for open circuit. Check all safeties. Clean or replace air filter. Check duct work and return air ducts for blockages.

WIRING DIAGRAM

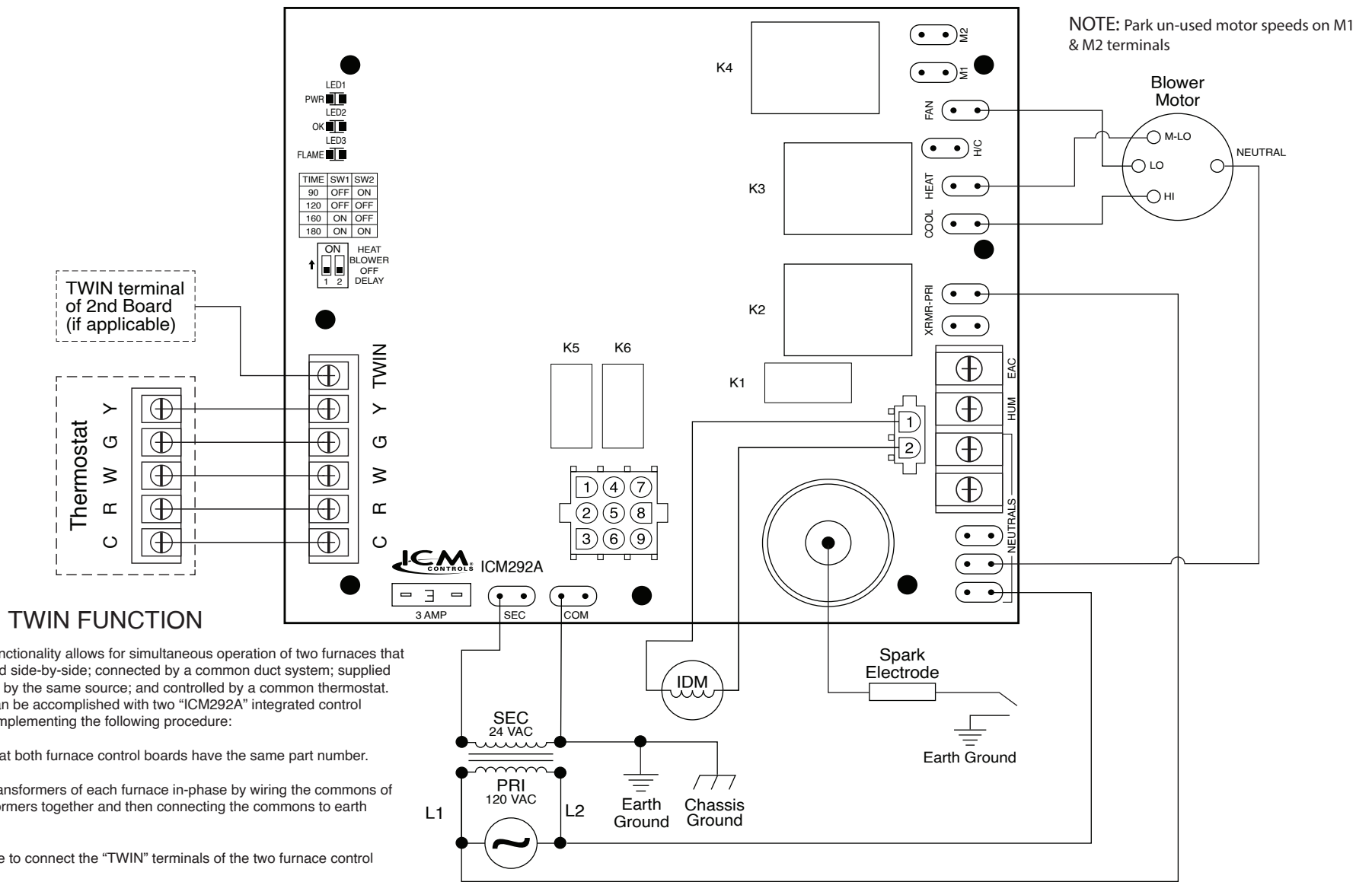

CONNECTION DIAGRAM

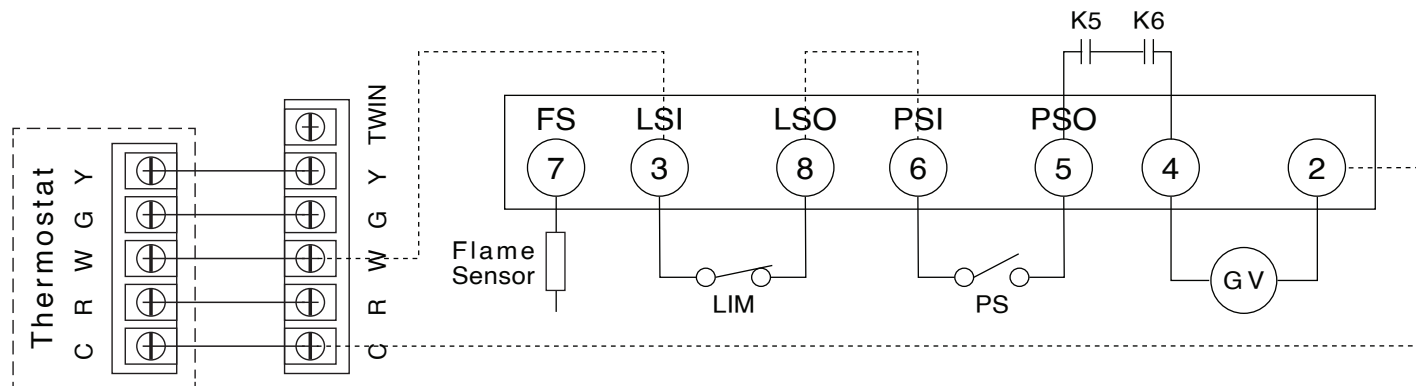

LEGEND

R	24 VAC	LIM	Limit switch
C	24 VAC Common	LO	Blower low speed
COM	Transformer secondary common	LSI	Limit switch in
EAC	Electronic air cleaner motor	LSO	Limit switch out
FS	Flame sensor	M-LO	Blower medium-low speed
GV	Gas valve	PRI	Transformer primary
H/C	Single-speed heat/cool	PS	Pressure switch
HI	Blower high speed	PSI	Pressure switch in
HUM	Humidifier motor	PSO	Pressure switch out
IDM	Induced draft motor	SEC	Transformer Secondary 24 VAC
K5, K6	Gas valve relays	XFMR-PRI	Transformer Primary 120 VAC

9-PIN CONNECTION

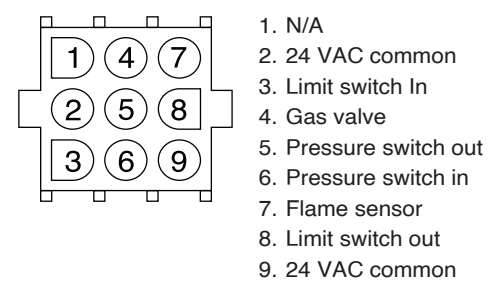

LIT P/N	ICM P/N	Size	Created by	MKT Signoff	Date	ENG Signoff	Date	DOC ID#	Date Added to DC