

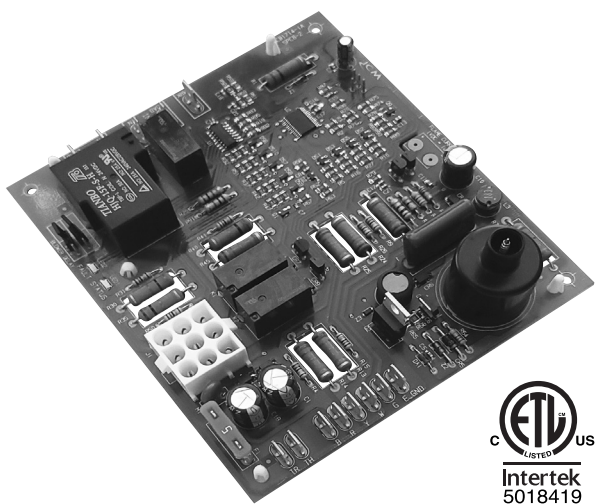

ICM2913

Gas Ignition Replacement Board



Installation, Operation & Application Guide

For more information on our complete range of American-made products – plus wiring diagrams, troubleshooting tips and more, visit us at www.icmcontrols.com

FEATURES

- Controls blower motors, gas valve, & spark ignitor in sequence
- Protects against short cycling
- Selectable Heat/Cool blower off-delay time
- Flash codes from the onboard LED indicate specific problems for easier troubleshooting
- Repeated ignition failures or flame losses will disable heat operation for safety

INTRODUCTION

The ICM2913 is a form, fit, and functional replacements for the boards shown in the cross-reference section of this guide. The control boards are designed as automated gas ignition controls which monitor the ignition sequence including the inducer, pressure switch, spark ignition, gas valve, flame sense, and circulating blower while maintaining full safety circuit monitoring including the high limit switch, roll out switch and auxiliary limit switch circuits. Onboard diagnostics will indicate when a fault condition exists.

SPECIFICATIONS

- Line voltage: 230 VAC
- Line frequency: 50/60 Hz
- Control voltage: 18-30 VAC
- Circulator blower: 10 FLA, 30 LRA @ 240 VAC
- Inducer blower: 0.7 FLA, 1.5 LRA @ 240 VAC
- Combined gas valve load: 1.5 A @ 24 VAC
- Minimum flame signal threshold: 0.75 μ A

REPLACES

TRANE P/N #: D674711P01

OPERATION

On a call for heat (24 VAC on the W input), the following occurs:

- Upon a call for heat the control checks the status of the pressure switch; if the pressure switch is open, the control will energize the draft inducer.
- When the control verifies the pressure switch has closed, the control will start a 20-second prepurge.
- When the pre-purge time delay is over, the control will energize the gas valve and initiate spark.
- The ignitor must be de-energized when the flame is sensed or at the conclusion of the trial for ignition period, whichever comes first.
- When flame is sensed, the control will energize the circulator fan within the ON-delay period.

When the call for heat is terminated, the following occurs:

- The control shall de-energize the gas valve and the draft inducer within the post purge period.
- When the heat mode fan OFF delay timer expires, the control will de-energize the circulator fan.

With a call for cooling, the following occurs:

On a call for cooling (24Vac on Y and G), the circulator fan is energized within the cool on delay period. The control will ignore a call for Y without a call for G. After the thermostat is satisfied, the compressor is de-energized and the jumper selected cool Off delay period begins. Following the cooling Off delay period, the circulator fan is de-energized.

ELECTROSTATIC DISCHARGE (ESD) PRECAUTIONS

Use caution when installing and servicing the furnace to avoid and control electrostatic discharge; ESD can impact electronic components. These precautions must be followed to prevent electrostatic discharge from hand tools and personnel. Following the precautions will protect the control from ESD by discharging static electricity buildup to ground.

1. Disconnect all power to the furnace. Do not touch the control or the wiring prior to discharging your body's electrostatic charge to ground.
2. To ground yourself, touch your hand and tools to a clean, metal (unpainted) furnace surface near the control board.
3. Service the furnace after touching the chassis. Your body will recharge with static electricity as you shuffle your feet or move around, and you must reground yourself.
4. Reground yourself if you touch ungrounded items.
5. Before handling a new control, reground yourself, this will protect the control. Store the used and new controls in separate, containers before touching ungrounded objects.
6. ESD damage can also be prevented by using an ESD service kit.

> > > CAUTION < < <

ELECTRICAL SHOCK HAZARD! Before installing this unit, turn off power at the main service panel by removing the fuse or switching the appropriate circuit breaker to the OFF position. Follow all Local, State and National Electrical Codes when installing this device.

CAUTION! Only trained personnel should install or service heating equipment. When working with heating equipment, be sure to read and understand all precautions in the documentation, on labels, and on tags that accompany the equipment. Failure to follow all safety guidelines may result in damage to equipment, severe personal injury or death.

REMOVE EXISTING CONTROL

CAUTION! To service control, and prior to disconnection, label all wires. Failure to do so may result in wiring errors that can cause dangerous operation.

1. Turn thermostat to the OFF position or set it to the lowest possible setting.
2. Turn OFF the electrical supply to furnace.
3. Turn OFF the gas supply to furnace.

CAUTION! Failure to turn off gas and electric supplies can result in explosion, fire, death or personal injury.

4. Remove the furnace blower and control access doors.
5. Disconnect the thermostat wires and humidifier wires (if equipped with a humidifier).
6. Disconnect the line voltage, blower, electronic air cleaner wires (if equipped) and transformer wires.
7. Remove screws and any other fasteners and the old circuit board.
8. Examine the control and the control box for water stains.
9. Make repairs if any sources of water leakage are found. Be sure to check humidifiers, evaporator coils and vent systems in the area of the control.

INSTALL NEW CONTROL

1. Ground yourself. When handling the circuit board; hold it by the edges.
2. Fasten the circuit board with the retaining screws.
3. Connect all line voltage, low voltage and accessory wires.
4. Verify the sequence of operation.

TIMING

(@ 25 VAC, 60 Hz, 25°C unless noted)

Function	Time	Units
Heat "ON" delay	45	Sec
Cool "ON" delay	2	Sec
Flame recognition time	0.8	Sec
Flame establishing period	7	Sec
Flame failure response time (before 10 seconds after trial for ignition period)	2	Sec
Flame failure response time (otherwise)	0.8	Sec
Recycle time	27	Sec
Lockout time	300	Sec
Pre-purge time	20	Sec
Post-purge time	5	Sec
Auto-restart purge time	5	Sec
Trial for ignition period	7	Sec
Interpurge time	60	Sec
Auto restart time	60	Min
Retry	2	Each
Recycle	10	Each
Heat fan OFF delay	60 or 90 sec., field selectable, default will be 90 sec.	
Cool fan OFF delay	0 or 45 sec., field selectable, 45 sec. will be default for HEM, 45 sec. will be default for PSC.	

SPECIAL FEATURES

Automatic Restart Purge

Lockout resets automatically after 1 hour. Whether a call is in place or not, the control activates the inducer blower for 5 seconds. The inducer will deactivate and ensure the pressure switch is not stuck closed before starting a new heat call.

Automatic Inducer Pre-purge Reset

If the pressure switch remains open after 2 minutes of draft inducer run time, the draft inducer will be de-energized for 30 seconds. The sequence will start again checking for an open pressure switch.

Continuous Fan Off delay (single stage units only)

On a call for continuous fan (24 VAC on G), the circulator fan is energized. During a call for cooling while the cool "On" delay is in place, the control will not respond to the fan input (G). If the fan was called prior to the call for cool, the circulator fan will remain energized during the Cool "On" delay. When the call for continuous fan is terminated, the selected cool Off delay period begins. When the cool Off delay period expires, the circulator fan is de-energized. **Note:** If the fan is called prior to a call for heat, the circulator fan will remain energized during the entire call for heat sequence.

Fault Code Retrieval

When powering on, the control flashes the last four error codes that have occurred in the last 14 days. The control will flash the newest error first and oldest error last. The fault memory can be manually erased by powering on with a G call in place and toggling W three times.

Flame Sense Test Points

The ignition board is equipped with a set of flame sense test points. A multimeter can be used to test flame sense by placing the meters probes on the two test pins and taking a DC voltage reading while the flame sensor is in the presence of flame. 1VDC = 1 μ A flame current. Weak or poor flame sense is represented by a reading of 0.7 VDC or lower.

LOCKOUT

The control will go into a 1-hour soft lockout if the following faults are detected:

- Limit switch open 4 times in one heat call
- Ignition failed (flame not sensed) 4 times in one heat call
- Flame lost after successful ignition 3 times in one heat call
- Gas valve sensed on when it should not be
- Gas valve sensed off when it should be on, 10 times in one heat call

Flame sensed while the gas valve is closed puts the control in lockout state, but lockout clears after the blower off delay is complete (90 seconds or 60 seconds, depending on jumper selection).

FAULT CODE TABLE

Fault code retrieval & clearing	# of Flashes	Error
When powering on, the control flashes the last four error codes that have occurred in the last 14 days. The control will flash the newest error first and oldest error last. The fault memory can be manually erased by powering on with a G call in place and toggling W 3 times.	2	External lockout (retries or recycles exceeded)
	3	Pressure switch/Inducer error
	4	Open limit switch and rollout
	5	Flame sensed when no flame should be present
	6	Not used
	7	External gas valve circuit error
	8	Low flame sense
	Solid Red	Internal board error
	Solid Red w/solid 'STATUS' LED	Continuous reset caused by an internal board error

Two LED's on the board

- Status LED (Green)
 - Slow Flash: Normal operation with no call for heat
 - Fast Flash: Normal operation with call for heat
- Fault LED (Red)
 - See table

TROUBLESHOOTING

Thermostat interference	There are some thermostats which can interfere with the way the ICM furnace boards sense the call for heat. If you are having any issues with establishing flame, the first step would be to remove all the thermostat wires from the board and temporarily jump R – W to test. If the furnace cycle completes, remove the jumper, and replace the existing thermostat with a battery-operated thermostat or a hardwired thermostat which uses a R & C connection.
Weak or intermittent spark	Make sure the furnace frame is grounded to earth ground. Ensure the common of the 24 VAC is grounded to Earth ground. Check or replace the spark igniter. Check the primary and secondary voltage of the transformer for proper voltage.
Flame Loss	<ul style="list-style-type: none"> • Check for bad or dirty flame sensor • Check thermostat (bypass for testing) • Check for proper flame sense signal at flame sense test pins • Check for proper earth ground on furnace. • 4 flame losses in a single heat call will put the control into a one-hour lockout.
No flame/ignition failure	<p>If the flame is not established and proven during the initial sequence, there will be two more successive attempts allowed each having a sixty second inducer purge between attempts. After three successive attempts if the flame is still not proven, there will be a 1 hour lock out before the system will try for ignition again.</p> <ul style="list-style-type: none"> • Check the thermostat (bypass for testing) • Check the pressure switch • Check gas valve operation • Check for good spark & check for good earth ground
Flame out of sequence	<p>Flame out of sequence represents a scenario where flame is sensed while the gas valve is closed. The control goes into a lockout state when flame is out of sequence and the indicator LED blinks the appropriate code (see “lockout” section).</p> <ul style="list-style-type: none"> • Check and replace flame sensor
Furnace does not ignite and main blower runs continuously	Check the high temperature limit switch for open circuit. Check all safeties. Clean or replace air filter. Check duct work and return air ducts for blockages.

WIRING DIAGRAM

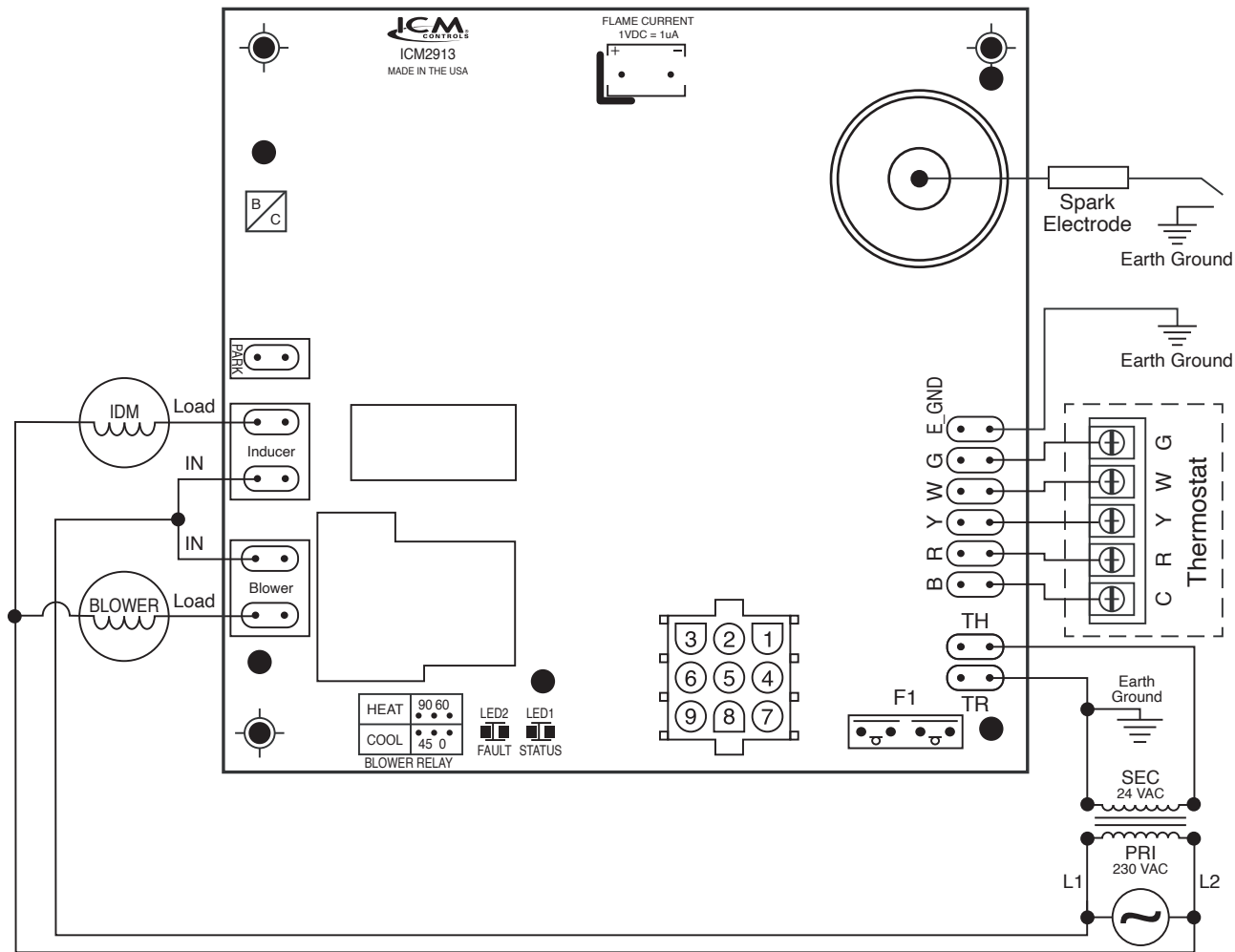

CONNECTION DIAGRAM

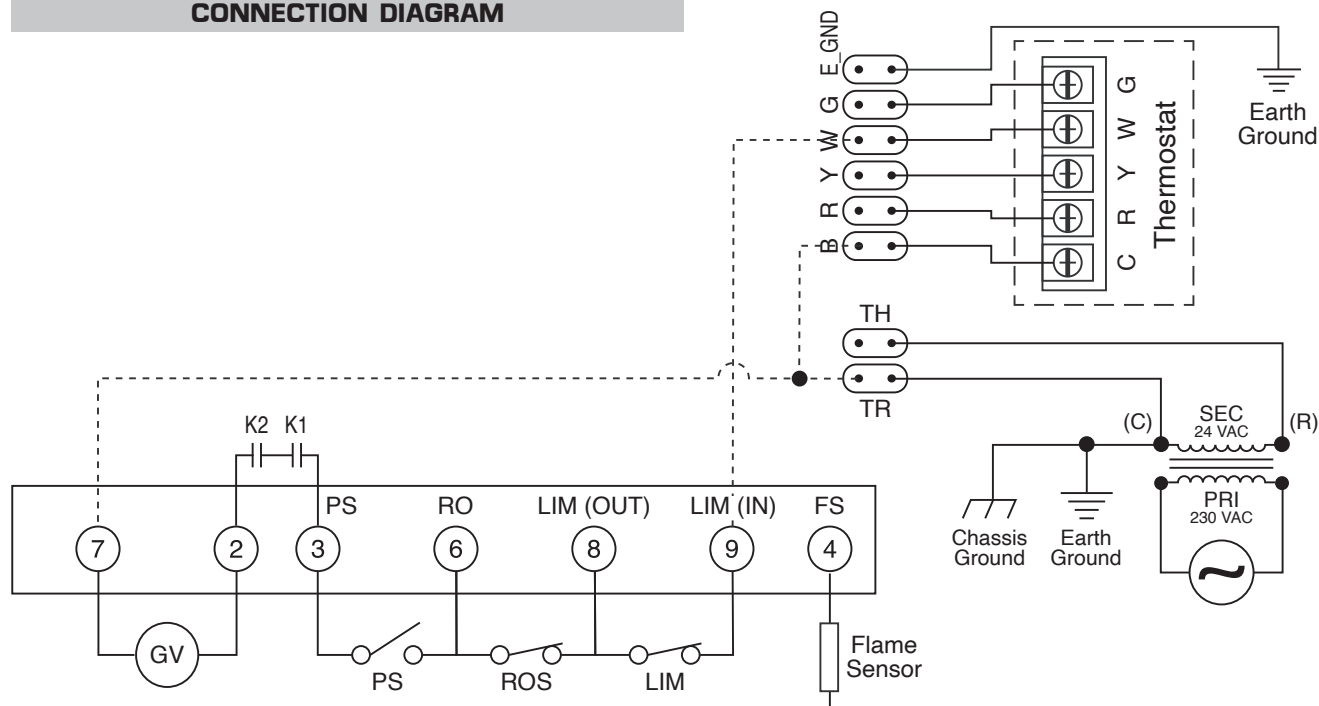

LEGEND

B	24 VAC common	LIM	Limit switch
C	24 VAC common	PRI	Transformer primary
ECM	N/A	PS	Pressure switch
F1	Fuse	R	24 VAC
FS	Flame sensor	ROS	Roll out switch
GND	Ground	SEC	Transformer secondary
GV	Gas valve	TH	Transformer 24 VAC hot
IDM	Induced draft motor	TR	Transformer 24 VAC common
K1, K2	Gas valve relays		

9-PIN CONNECTION

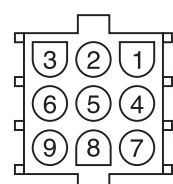

1. N/A
2. Gas valve
3. Pressure switch in
4. Flame sensor
5. N/A
6. Fusible link (Roll out switch)
7. Common (24 VAC), B
8. Limit switch (out)
9. Limit switch (in)