



ICM442

Three-Phase Motor Control



Installation, Operation & Application Guide

For more information on our complete range of American-made products – plus wiring diagrams, troubleshooting tips and more, visit us at www.icmcontrols.com



Caution

The **ICM442** should be installed by trained technicians only. Adhere to all local and national electric codes. Disconnect all power before installing.

Specifications

Input

- **3-Phase Voltage:** 200-575 VAC
- **Frequency:** 50/60Hz
- **Thermistors:** Four (4) 100Ω thermistors in series

Output

- **Relay Rating:** 250 VAC at 10 A

Mode of Operation

The **ICM442** protects a three-phase motor using up to four thermistors in series. When at least one (1) of the thermistors has a resistance over 4.5kΩ the relay on the **ICM442** will de-energize the contactor on the motor. When the total resistance of the thermistors returns to 2.75kΩ, the **ICM442** will re-energize the relay and, in turn, the contactor. When there is a phase reversal, four (4) consecutive phase loss faults, or ten (10) phase loss faults in a 24 hour period, the **ICM442** will enter lockout. To clear the lockout, power cycle the unit.

Installation



ELECTRICAL SHOCK HAZARD – Turn off power at the main service panel by removing the fuse or switching the appropriate circuit breaker to the OFF position.

1. Remove power from the motor.
2. Connect up to four 100Ω thermistor in the motor windings in series.
3. Connect the thermistor circuit to the TH- and TH+ terminals on the **ICM442**, using female ¼” quick-connects.
4. Connect phase voltages as shown in “Wiring Diagram”, using female ¼” quick-connects.

5. The motor has a contactor that supplies the operating current to the motor. Connect one side of the contactor to the COM terminal on the **ICM442**, using a female ¼” quick-connect.
6. The other side of the contactor controls safety switches (thermostat, pressure switch, etc.). Connect that side of the contactor to the NO terminal on the **ICM442**. Consult “Wiring Diagram” with any questions.
7. Verify correct wire connections.
8. Turn on power to the unit.

Wiring Diagram

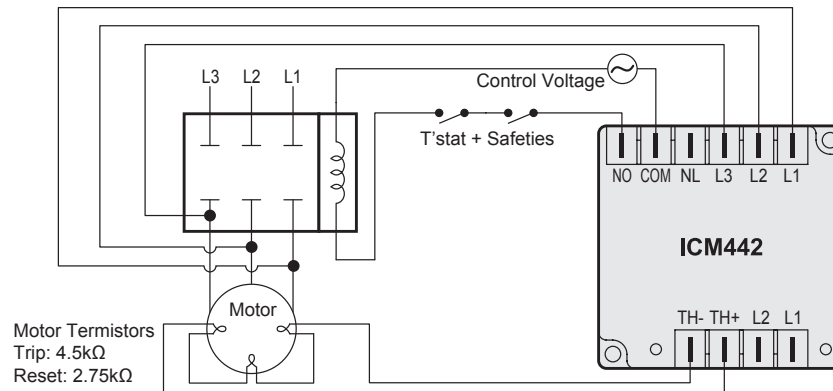

Troubleshooting

Problem	Possible Cause	Corrective Action
Motor will not energize	No power	Verify power to the unit.
	Unit in lockout	Power cycle the unit to clear lockout.
	Motor over temperature	Using an Ohm meter, with the power disconnected to the motor, verify the connected motor winding thermistors are less than 4.5kΩ.
Motor turns off within 5 seconds of contactor energizing	Phase Loss	The unit will re-energize the relay and motor contactor after 6 minutes. The unit will enter lockout conditions when there are 4 consecutive phase loss faults or 10 phase loss faults in a 24 hour period.
	Phase Reversal	Power cycle the unit to clear lockout.
Motor turns off after being energized for an extended period of time	Motor over temperature	The relay in the ICM442 will re-energize the contactor in the motor 5 minutes after the thermistors have reached 2.75kΩ.