

Replaces: Goodman PCBFM103 and PCBFM103S

### SPECIFICATIONS

#### Input

- **Control Voltage:** 18-30 VAC
- **Frequency:** 50/60 Hz

#### Output

- **Type:** Relay
- **Form:** SPDT
- **Rating:** 25 amps @ 240 VAC, N.O.

#### Time Delays

- **ON Delay:** 7 seconds
  - **OFF Delay:** 65 seconds
- Speed Up Options**
- Speed up to C = Reduced delay (3 sec. ON, 5 sec. OFF)
  - Speed up to R = No delay

#### Environmental

- -20°F to 200°F
- 5% to 95% non-condensing

#### Timing Diagram

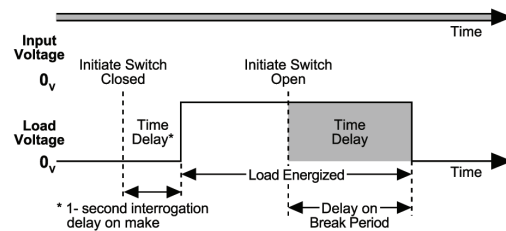

### MODE OF OPERATION

Upon application of power to the G terminal, the ICM256 recognizes a call for the blower and a 7 second delay on make period begins. After the 7 second ON delay, the control energizes the blower motor. Upon removal of power from the G terminal, the board will keep the blower on for an additional 65 seconds. At the end of the 65 second OFF delay, the blower will shut off.

### WIRING DIAGRAM

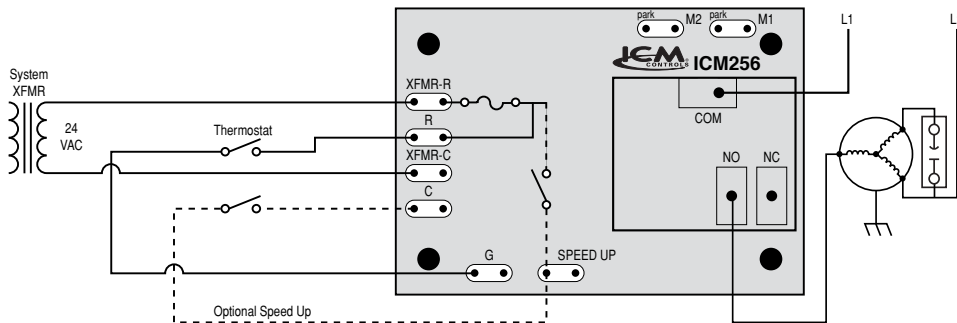

### TROUBLESHOOTING

Problem	Solution
Fan will not turn on	Check fuse (F1) Check for 24 VAC at R & C. Check for thermostat call
No delay or reduced delay	Make sure the board is not in test mode

Replaces: Goodman PCBFM103 and PCBFM103S

### SPECIFICATIONS

#### Input

- **Control Voltage:** 18-30 VAC
- **Frequency:** 50/60 Hz

#### Output

- **Type:** Relay
- **Form:** SPDT
- **Rating:** 25 amps @ 240 VAC, N.O.

#### Time Delays

- **ON Delay:** 7 seconds
  - **OFF Delay:** 65 seconds
- Speed Up Options**
- Speed up to C = Reduced delay (3 sec. ON, 5 sec. OFF)
  - Speed up to R = No delay

#### Environmental

- -20°F to 200°F
- 5% to 95% non-condensing

#### Timing Diagram

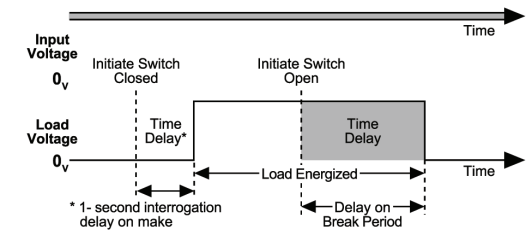

### MODE OF OPERATION

Upon application of power to the G terminal, the ICM256 recognizes a call for the blower and a 7 second delay on make period begins. After the 7 second ON delay, the control energizes the blower motor. Upon removal of power from the G terminal, the board will keep the blower on for an additional 65 seconds. At the end of the 65 second OFF delay, the blower will shut off.

### WIRING DIAGRAM

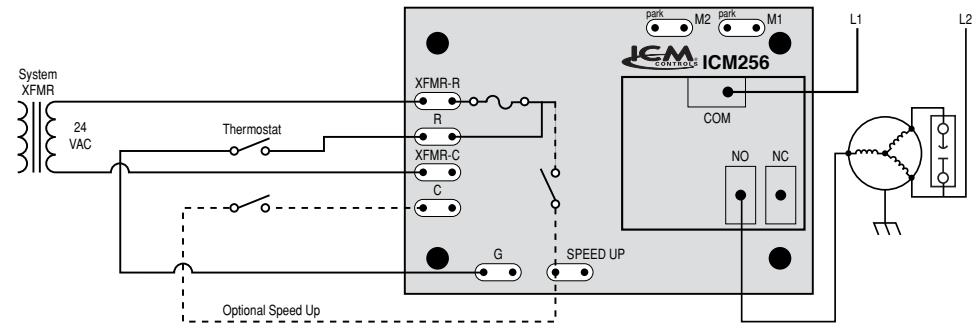

### TROUBLESHOOTING

Problem	Solution
Fan will not turn on	Check fuse (F1) Check for 24 VAC at R & C. Check for thermostat call
No delay or reduced delay	Make sure the board is not in test mode

